

Draft



abstracta

www.abstracta.se



Draft

Design Daniel Lavonius Jarefeldt & Josef Zetterman (Tengbom arkitekter)



Dagens arbete blir mer och mer flexibelt. Behovet av en egen arbetsplats och fasta mötesrum är inte längre en självklarhet.

Draft är en mobil, dubbelsidig skrivtavla med en grafisk och enkel form.

Work nowadays is becoming increasingly flexible. Fixed workplaces and meeting rooms are no longer obvious requirements.

Draft is a mobile, double-sided writing board with a simple graphic form.



Dubbelsidig, vit skrivyta med E3, glasemaljerad, magnetbärande stålplåt.

Double-sided, white writingboard E3, enamel magnetic steel sheet.



Under skrivytorna finns en trälåda, för förvaring av t ex pennor och sudd. Trälådan i ek adderar värme till produktens uttryck.

Below the writing surfaces is a wooden drawer for storing pens and erasers, for example. The wooden drawer is made from oak and adds a warm feeling to the expression.



Tavlan har ett antracitgrått stålstativ med låsbara hjul.

The board has an anthracite grey steel frame with lockable castors.





JAMES'
ONLY
UNIT
IS IN A
HURRY

Alumi Alkov
Designing Jobs



Teknisk information/Technical information

Mått Draft mobil skrivtavla
/Measurements Draft mobile writing board

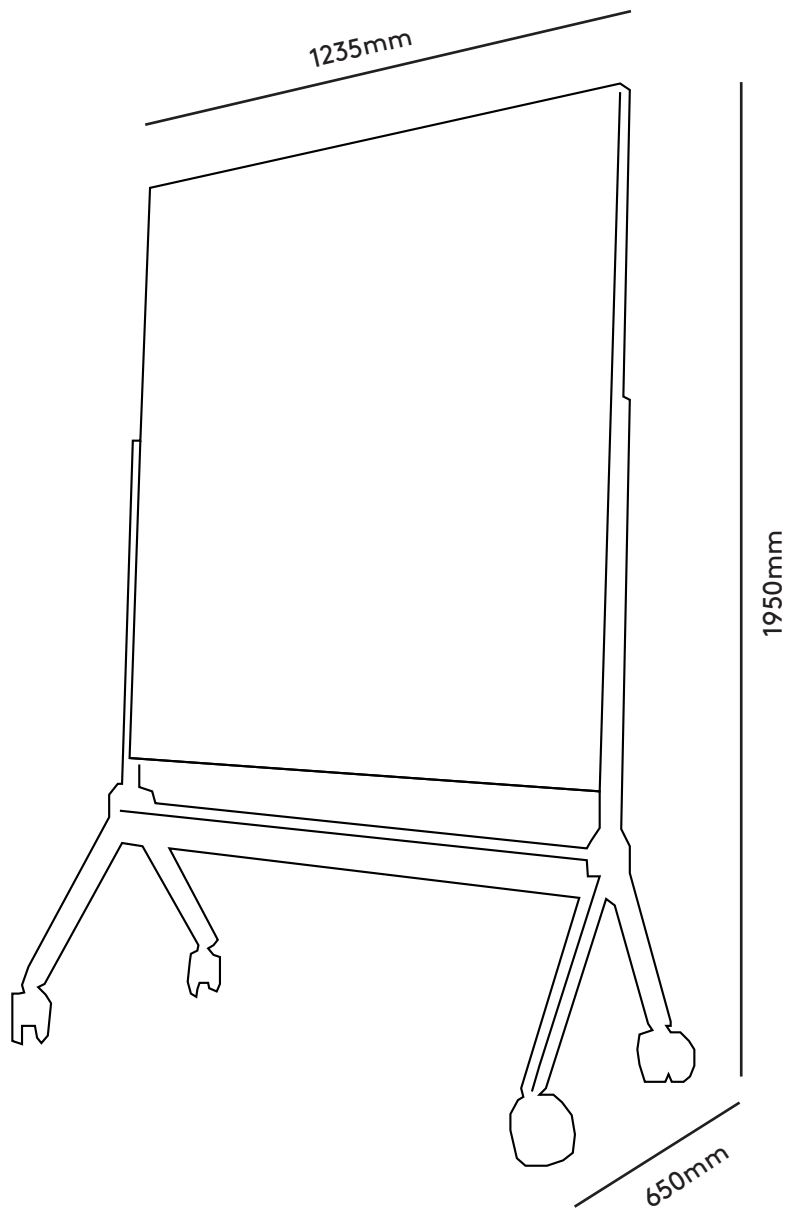

Every whiteboard in the Abstracta range has an E3 surface; an environment-friendly, glass enamelled, sheet of steel. The writing surface is magnetic. E3 is recommended for short throw projectors only.

A special "White board kit" is available as an accessory This has been developed to fit the E3 surface and includes: eraser, markers, penholder, bottle of cleaning fluid and magnets.

abstracta

Box 75, Lammengatan 2, SE-360 30 Lammhult, Sweden

T +46 472 26 96 00, F +46 472 26 96 01

info@abstracta.se

www.abstracta.se