



Weblink
1399

Project page
254

Restaurant 3950, Mandalay Bay Hotel & Casino, Las Vegas, Nevada, USA. Architect: Klai Juba Architects. Lighting designer: Klai Juba Architects. Photo: Clearlight

Design
Poul Henningsen

Concept
PH 4½-4 Glass Pendant provides soft lighting. The PH 4½ family is designed on the principle of a reflecting multi-shade system, creating harmonious and glare-free lighting. The shade design is based on a logarithmic spiral, with the centre of the light source placed in the spiral's focal point.

Finish
White opal glass. High lustre chrome plated.

Material
Shades: Mouth-blown white opal glass. Anti-glare disc: Purple, spun aluminium. Suspension: High lustre chrome plated, extruded aluminium.

Mounting
Suspension type: Cable 3x0.75mm² & wire. Canopy: Yes. Cable length: 3m.

Weight
Max. 3.5kg.

Class
Ingress protection IP20. Electric shock protection I w. ground. ⚡

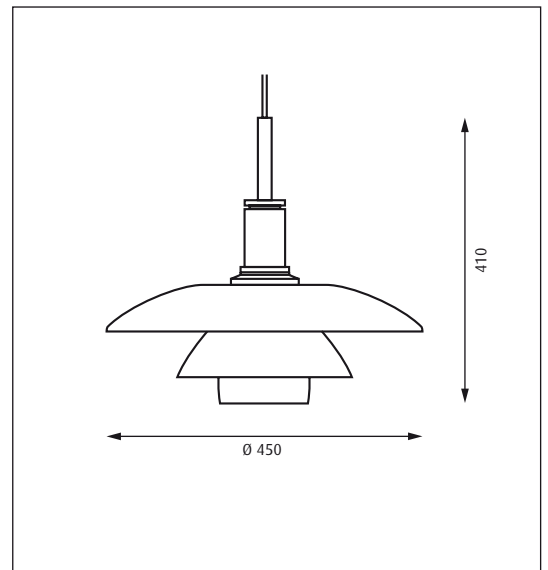

Product code	Light source	Finish	Cable type
PH4.5G-P	1x150W A65 Frosted E27	WHT OPAL GLASS	BLK TEX/WIRE

Information:
Find energysaving alternative light sources on www.louispoulsen.com.

