

design made in germany

Wilkhahn

Logon.
620 range





Logon range

Design: Andreas Störiko

The engineering principle, inspired by aircraft construction, allows maximum stability with minimum structure. The elegant table appears to have floating surfaces. The example shows a linked 90° solution finished with oak veneer stained dark, clear anodized uprights and polished foot sections.



Versatile table culture.

A table is perhaps the most important element of furniture for influencing togetherness within a company. In a meeting at the workplace, in a conference or in an executive's office – this is where people meet to assure themselves of their common identity and to develop new ideas.

For companies that assign as much value to openness, lightness and dynamics as to high-level quality and enduring elegance, the Logon range offers table culture of the highest degree of excellence and design quality. The rounded laminated wood lipping with integral, impact-resilient profile, the slender uprights and the elegantly modelled foot sections in die-cast aluminium provide an abundance of options for individual tables and table configurations with an appearance of transparent, optical lightness. An ingenious tensioning principle, drawn from aircraft construction, permits minimum material thicknesses.

Logon provides a perfect solution to virtually all requirements for tables – as a single table or a linked configuration, on adjustable glides for levelling out floor irregularities or on castors for mobile application. From reception areas and meeting rooms to large-scale conference layouts, from robustness for application in project offices to an executive boardroom. All in a distinctive and coherent design language that communicates future-oriented awareness.



Prestigious, barrel-shaped table configuration in cherry veneer with anodized uprights and bright chromium-plated foot sections to seat 20. Tilt-up techni-stations for serving digital projectors are integrated into the table tops. A perfect team: Modus cantilever chair with elegantly stitched, slim cushion.

A management workplace with Modus Executive, perfectly matched with the conference configuration: the large single tables, measuring up to 240 x 120 cm (94½" x 47¼"), cut an excellent figure as a workplace. The modesty panel in fluted, extruded aluminium profile also functions as cable management and may be fitted to any type of table configuration.



Logon. Understated – yet intriguing.

The extremely optically light, aesthetic impression made by Logon tables is due to an ingenious principle inspired by aircraft construction: foot sections and table top bearers are firmly braced by means of threaded rods in the uprights. Minimum material cross sections can therefore be used to achieve a particularly high degree of stability. The result: a table surface of 240 x 120 cm (94½" x 47¼") that appears to have floating surfaces and does not require any additional bracing. The recessed underframe ensures spacious legroom and versatile seating layouts. For both a desk and a linked conference configuration.

The precisely modelled foot sections and the table top bearers are in high-grade die-cast aluminium. The vertical uprights and the horizontal underframe comprise extruded aluminium profile. Besides standardized sizes and formats, the modular frame structure allows customized table configurations that are exactly coordinated with individual interior forms and space requirements.





Open-centred, oval table arrangement to seat 32: a free-standing segment has been inserted at the front of the linked configuration to allow the space in the centre to be accessed. Microphone modules and table "portals" for all network connections have been integrated into the customized table top segments. The version with pale laminate tops, solid wood lipping with integral impact-resilient profile and bright chromium-plated frames withstands a high level of wear without leaving signs of use. Comfortable, light, stackable Sito cantilever models have been selected as seating.



Excellence in detail: the bright chromium-plated frame and the cantilevered table top with the distinctive impact-resilient profile integrated into the solid wood lipping convey quality and elegance. They harmonize perfectly with the bright chromium-plated armrests and frames of the luxurious Modus conference chair.



Elongated, open-centred table configuration for 18. Modus conference chairs with automatic synchro-adjustment and self-centring mechanism create a calm, ordered appearance, while providing first-class ergonomic comfort for longer periods of sitting too.

Logon. Decision-maker.

If decision-makers are expected to take a high degree of responsibility, a conference room should be furnished and equipped to promote processes focused on agreement and decision in the most optimal manner. For example, by means of a table configuration with rounded long edges to encourage interaction and communication among conference participants. The exposed places at the sides facilitate more tightly steered, more goal-oriented conference management. Participants can use digital projection for visual presentation of their ideas by means of integral table "portals" housing plug-and-play modules for media, power supply and network connections.

The functionality of the table configuration is as important as high quality. A boardroom does after all symbolize the value that a community assigns to meetings held there. With this in mind, table frames with a bright chromium-plated finish and solid wood lipping have been selected that convey precision and elegance as convincingly as the high quality of the leather-covered Modus conference chairs.



Conference table in a boardroom: the single table with a barrel-shaped top with pear veneer provides ample space for six. Modus cantilever chairs, featuring a bright chromium-plated frame, seats with leather cushions and a back with semi-transparent stretch fabric, and the Avera seating arrangement for informal communication are coordinated with the frame and surface finish of the Logon table.



Logon. Infinite variety.

Circle or rectangle, monolithic or compact – with Logon you can let your spirit fly. The modular structure of the table frames provides solutions for table depths from 75 (29½") to 120 cm (47¼") for single tables, and up to 260 cm (102¾") for linked configurations; 45° and 90° corner solutions are available as serial elements, and intermediate sizes may be customized by the Wilkhahn Customized Manufacturing Centre. The result is maximum versatility in terms of form and format that may be tailored to meet individual requirements. With the unmistakable distinctiveness, aesthetics and quality of serial models. For a table culture that will continue to stand for future-oriented awareness and perfection in many years to come.

Please contact us for personal consultation to find the optimal solution to suit your individual requirements. Our staff will be delighted to assist you.

Starting element,
intermediate element
and finishing element
create an elongated,
classic table configura-
tion for ten.



With either coherently designed table 'portals' or high-quality, flush-mounted techni-modules – the functional and design versatility of the integral selected modules provides the right solution to suit any demands.

Logon. Versions, accessories and integral techni-modules.

Standard versions of Logon comprise surface finishes in laminate, linoleum and real wood veneer. Leather inserts or metal surfaces may also be integrated into table tops.

Foot sections are optionally in the colour silver or black, clear anodized, polished or bright chromium-plated. This allows finely tuned coordination with the ambience of the conference interior – with existing seating, an architectural feature or a functional element.

Not only are Logon surface finishes, formats and forms customized to meet your requirements, but also the inclusion of state-of-the-art conference technology: ranging from cable outlets, tilt-up techni-stations with a choice

of different modules for "plug-and-play" solutions to the integration of telephone conference modules, complete AV systems, digital projectors or retractable displays. The result is customized solutions where technology is an integral part of the table configuration and is largely optically concealed.

Wilkhahn is, after all, regarded as the global pioneer of providing support for conference processes by means of integrated communication and information technologies. We would be delighted to analyze your requirements together with you to find the concept that provides you with an optimal solution.



The suspended Logon modesty panel in fluted, extruded aluminium profile provides both a degree of privacy as well as concealed cable management.

Logon.
 Confair folding table.
 Timetable.
 Fixed or mobile –
 a strategically coordinated
 game-plan.

A distinctive communication and table culture is not only of paramount importance at the workplace, in meeting or conference rooms but also in interiors intended for multifunctional application. In addition to the Logon table range, designer Andreas Störiko has therefore also developed the (now) legendary Confair folding table and the pivotable Timetable for Wilkhahn. They combine unique aesthetics with ingenious functionality and easy handling. And ensure that fixed table elements can be combined with mobile, dynamic single tables in versatile, partitionable interiors.

The unmistakable "family resemblance" of Andreas Störiko's designs derives from three typical features: the rounded laminated wood lipping with integral, impact-resilient profile, the slender uprights and the elegantly modelled foot sections in die-cast aluminium. For a communication and table culture in a coherent design language.



Folding table from the Confair range, design Andreas Störiko: just one swift movement – and a 260 x 110 cm (102 $\frac{3}{8}$ " x 43 $\frac{1}{4}$ ") table invites you to take a seat. Dynamic, creative, space-saving – and a model of excellence. The range has won some of the highest international design awards and has a firm place on many an executive floor too.



Timetable range, design Andreas Störiko: a patented mechanism allows a Timetable to be pivoted along the horizontal axis with one simple movement, which automatically causes the foot sections to rotate. This permits Timetables to be compacted effectively in ordered columns.

Formats. Materials. Surfaces.

Function

Single tables for application in offices, and system components for permanently linked table configurations in conference rooms. Ideal for combining with Confair folding tables for versatile, partitionable conference rooms.

Frame

Foot section in die-cast aluminium, chromium-plated, polished or coated according to Wilkhahn colour samples. Aluminium profile uprights, clear anodized, bright chromium-plated or coated. Die-cast aluminium table top bearer coated in either platinum or black, depending on foot section version.

Aluminium profile underframe coated in the colour platinum or black, depending on foot section version. Centre underframe for table depths 75 (29½") and 90 cm (35⅝"); two separate underframes for table depths 105 (41⅜") and 120 cm (47¼"). Adjustable glides in black polyamide; lockable castors in black polyamide (models 621/5 and 623/51 only).

Table tops

Particle board with concealed solid wood lipping or laminated wood lipping and integral, impact-resilient polypropylene profile in black; system elements with straight edge without profile. Top surfaces optionally in laminate, real wood veneer according to Wilkhahn woodstain colour samples (table top thickness 27 mm (1⅛")) or linoleum (table top thickness 30 mm (1⅞")).

Modesty panels

Fluted, extruded aluminium profile, clear anodized or coated black. Screw connectors to table top, clear anodized.

In addition to standard versions of table ranges, many customized options are also available. Forms, dimensions, surface finishes and prices on request.

Subject to technical change without notice.

Special formats

In addition to standard formats, the engineering principle allows an abundance of options for configuring customized table configurations: for example, compact, square arrangements comprising four triangular segments; barrel-shaped forms or open-centred table configurations that are individually coordinated with space dimensions and forms of interaction.

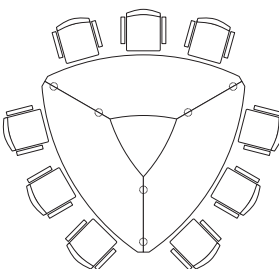
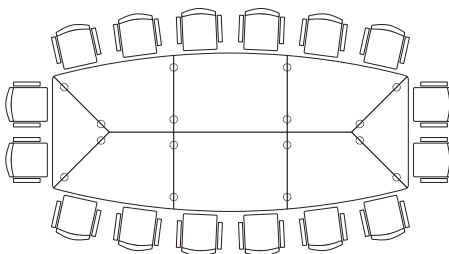
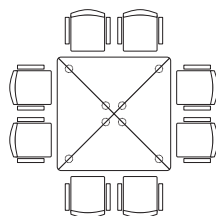

Duplicate – divide – remove.

The key is ingenious layout planning: conference interiors with prestigious, high-quality furniture may be used for varied applications with a combination of linearly linked Logon elements and Confair folding tables in coordinated dimensions. In this example, two conference rooms for 22 participants each can be transformed into an open forum layout to accommodate 40, or also into a banquetting hall with four long, spacious tables, each seating 12. In the latter case, the folding tables would then be used for a buffet.

- 4 x Logon starting element 120 x 180 (47¼" x 70⅞")
- 4 x Logon intermediate element 120 x 150 (47¼" x 59")
- 4 x Logon finishing element 120 x 180 (47¼" x 70⅞")
- 4 x Confair folding table 120 x 240 (47¼" x 94½")

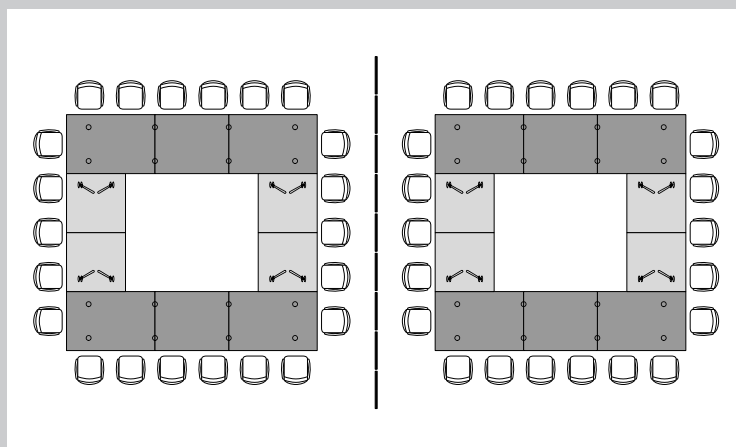

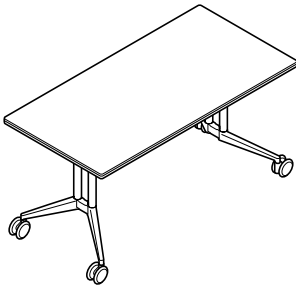

621/5, 75x150 (29½" x 59"), with castors
621/1, 75x150 (29½" x 59"), with glides
621/3, 75x225 (29½" x 88⅝"), with glides

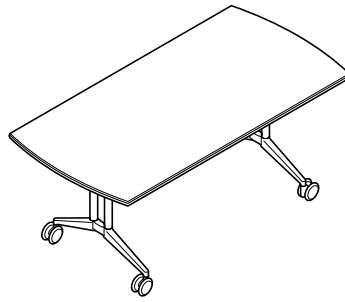

623/51, 90x180 (35⅜" x 70⅞"), with castors

90 x 180 (35⅜" x 70⅞") optionally infinitely adjustable in height; table widths 180/240 (70⅞" /94½") rounded on short edges.

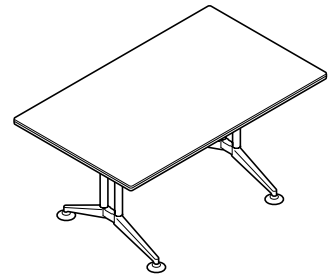

Model group:
623, table depth 90 90x150/180/240 (35⅜" x 59" /70⅞" /94½")
625, table depth 105 105x180/240 (41⅜" x 70⅞" /94½")
627, table depth 120 120x180/240 (47¼" x 70⅞" /94½")

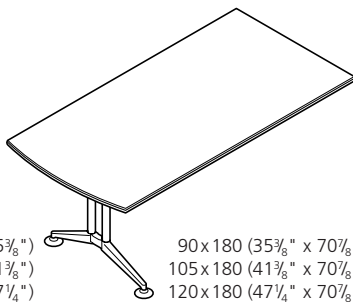

Model group:
624, table depth 90 (35⅜") 90x180 (35⅜" x 70⅞")
626, table depth 105 (41⅜") 105x180 (41⅜" x 70⅞")
628, table depth 120 (47¼") 120x180 (47¼" x 70⅞")

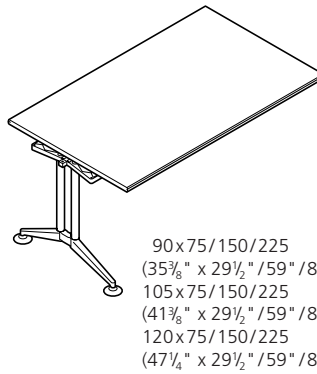

90x75/150/225 (35⅜" x 29½" /59" /88⅝")
 105x75/150/225 (41⅜" x 29½" /59" /88⅝")
 120x75/150/225 (47¼" x 29½" /59" /88⅝")

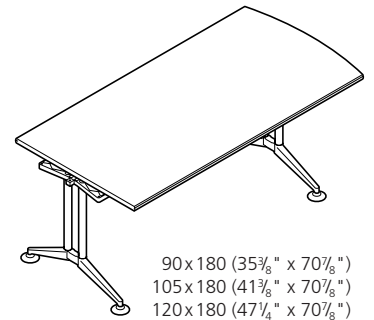

90x180 (35⅜" x 70⅞")
 105x180 (41⅜" x 70⅞")
 120x180 (47¼" x 70⅞")

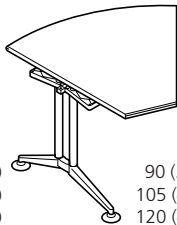

Model group:
624, table depth 90 (35⅜") 90 (35⅜") in 45°
626, table depth 105 (41⅜") 105 (41⅜") in 45°
628, table depth 120 (47¼") 120 (47¼") in 45°

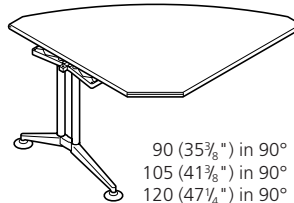

90 (35⅜") in 90°
 105 (41⅜") in 90°
 120 (47¼") in 90°

All dimensions in cm/inches.

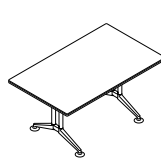

Logon

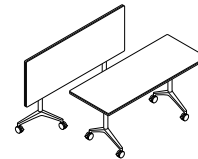

Timetable

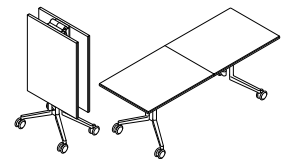

Confair folding table

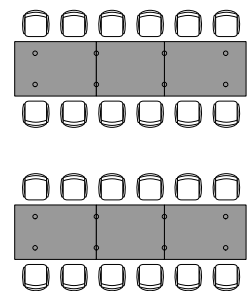
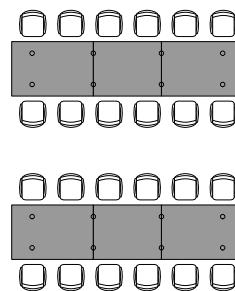
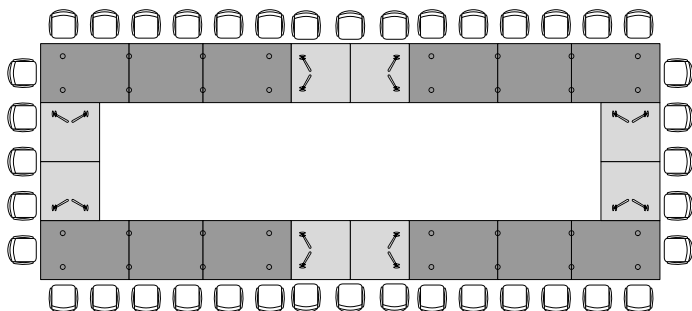

Wilkhahn

Wilkening + Hahne GmbH+Co. KG
Fritz-Hahne-Straße 8
31848 Bad Münder
Germany
Tel. + 49 (0) 5042 999-0
Fax + 49 (0) 5042 999-226
info@wilkhahn.de
www.wilkhahn.de

Australia
Wilkhahn Asia Pacific
Head Quarters
Wilkhahn Forum Sydney
A2, Alexandria Industrial Estate
46-62 Maddox Street
Alexandria NSW 2015
Tel. + 61 (2) 9310 3355
Fax + 61 (2) 9319 5655
info@wilkhahn.com.au

Wilkhahn Forum Brisbane
2/40 Douglas Street
Milton QLD 4064
Tel. + 61 (7) 3369 2088
Fax + 61 (7) 3369 3088
info@wilkhahn.com.au

Wilkhahn Forum Melbourne
Level 1, 423 Bourke Street
Melbourne VIC 3000
Tel. + 61 (3) 9670 5570
Fax + 61 (3) 9670 5535
info@wilkhahn.com.au

Belgium
Wilkhahn
Oude Leeuwenrui 7-11
2000 Antwerpen
Tel. + 32 (0) 3 232 93 91
Fax + 32 (0) 3 227 16 16
info@wilkhahn.be

Central and Eastern Europe
Wilkhahn Poland
Focus Building
Ul. Armii Ludowej 26
00-609 Warszawa
Tel. + 48 (0) 22 579 77 55
Fax + 48 (0) 22 579 77 56
info@wilkhahn.pl

China
Wilkhahn Asia Pacific
Wilkhahn Forum Shanghai
Suite 7602, Building 7
No. 10 Jian Guo Zhong Road
Lu Wan District
Shanghai 200025
Tel. + 86 (21) 5466 1919
Fax + 86 (21) 5465 1642
info@wilkhahn.com.au

España
Wilkhahn S. A.
Apolonio Morales, 6
28036 Madrid
Tel. + 34 91 515 85 80
Fax + 34 91 411 46 86
info@wilkhahn.es
www.wilkhahn.es

France
Wilkhahn S.à r.l.
Hôtel industriel Berlier
15 rue Jean-Baptiste Berlier
75013 Paris
Tél. + 33 (0) 1 44 23 76 70
Fax + 33 (0) 1 44 23 76 75
info@wilkhahn.fr

Great Britain
Wilkhahn Ltd.
Wilkhahn Forum London
Morelands
5-23E Old Street
London EC1V 9HL
Tel. + 44 (0) 20 73 24 29 00
Fax + 44 (0) 20 73 24 29 01
info@wilkhahn.co.uk

Hong Kong
Wilkhahn Asia Pacific
Wilkhahn Forum Hong Kong
Shui On Centre, Unit 907
6-8 Harbour Road, Wanchai
Tel. + 852 2827 0800
Fax + 852 2827 0855
info@wilkhahn.com.au

Japan
Wilkhahn Japan Co., Ltd.
Axis Building 3F
5-17-1 Roppongi
Minato-ku
Tokyo 106-0032
Tel. + 81 (0) 3 5573 2411
Fax + 81 (0) 3 5573 2413
info@wilkhahn.co.jp
www.wilkhahn.co.jp

Malaysia
Wilkhahn Asia Pacific
Wilkhahn Forum Kuala Lumpur
Menara Haw Par, Suite 29.02
Jalan Sultan Ismail
Kuala Lumpur 50250
Tel. + 60 (3) 2072 8077
Fax + 60 (3) 2072 1868
info@wilkhahn.com.au

Nederland
Wilkhahn Forum Rotterdam
Van Nelle-Ontwerpfabriek
Van Nelleweg 3138
3044 BC Rotterdam
Tel. + 31 (0) 10 750 33 90
Fax + 31 (0) 10 750 33 91
info@wilkhahn.nl

North America
Wilkhahn Inc.
Wilkhahn Forum New York
10th floor
601 West 26th Street
New York NY 10001
Tel. + 1 212 229 9455
Fax + 1 212 229 4772
info@wilkhahn.com

Österreich
Wilkhahn Handelsges.m.b.H.
Wimberggasse 12
Kundeneingang Kaiserstraße 69
1070 Wien
Tel. + 43 (0) 1 894 21 68-0
Fax + 43 (0) 1 890 32 39-15
info@wilkhahn.at

Schweiz
Wilkhahn AG
Postgasse 17
Postfach 808
3000 Bern 8
Tel. + 41 (0) 31 310 13 13
Fax + 41 (0) 31 310 13 19
info@wilkhahn.ch
www.wilkhahn.ch

Singapore
Wilkhahn Asia Pacific
Wilkhahn Forum Singapore
61 Alexandra Terrace
#07-03 Harbour Link
Singapore 119936
Tel. + 65 622 111 86
Fax + 65 622 111 25
info@wilkhahn.com.au

South Africa
Emergent Office Solutions Pty. Ltd.
P.O. Box 2963
Johannesburg 2000
Tel. + 27 (0) 11 575 00 44
Fax + 27 (0) 11 576 19 35
info@emergent.co.za
www.emergent.co.za

United Arab Emirates
Wilkhahn Middle East
DAFZA Phase 4
Block A
Office 132
Dubai
Tel. + 971 42 04 51 32
Fax + 971 42 04 51 34
info@wilkhahn-me.com