



Weblink
1400

332, 342, 370, 374

Studio. Photo: Kaslov studio

Design
Poul Henningsen

Concept
PH 5 provides glare-free lighting. The design of the visible reflectors directs light both vertically and horizontally. The inside cone is painted red, and together with the small blue reflector, it creates a warm tone of light.

Finish
Chili Red, coconut white, mint blue, olive black or wasabi green, lacquered. White, wet painted.

Material
Shades: Spun aluminium. Anti-glare disc: Blue or red, spun aluminium. Struts: Aluminium coloured or purple, rolled aluminium.

Mounting
Suspension type: Cable 3x0,75mm². Canopy: Yes. Cable length: 3m.

Weight
Max. 2,5kg.

Class
Ingress protection IP20. Electric shock protection I w. ground. F-mark: Yes.

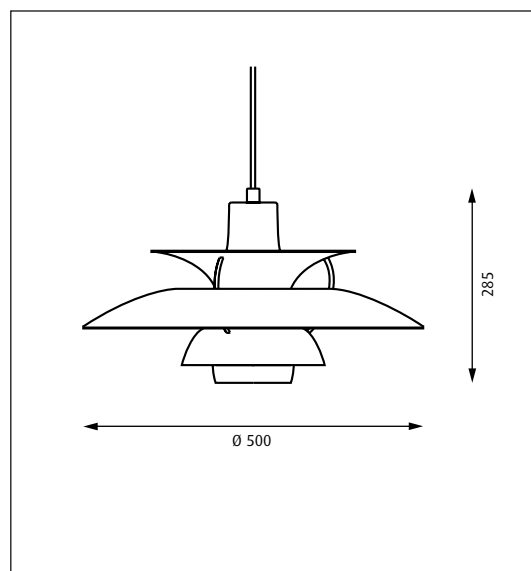

Product code	Light source	Finish	Cable type
PH5/PH50-P	1x23W TC-TSE/1x200W A80 E27	WHITE CHILI RED COCONUT WHITE MINT BLUE OLIVE BLACK WASABI GREEN	WHT TEX

Info notes:
PH 5 is wet-painted in a matt surface. PH 50 is wet-painted in a high-lustre surface. Find energy-saving alternative light sources on www.louispoulsen.com



Olive Black Wasabi Green Chili Red Coconut White Mint Blue