



Natural Wedge. Tokyo, Japan. Architect: Masaki Endoh + Masahiro Ikeda. Contractor: Ridea Construction Co., Ltd. Photo: Tetsuo Ishii, SS Tokyo

**Weblink**  
1434

**Design**  
Arne Jacobsen

**Concept**  
AJ Wall has a fixture head with a distinct, asymmetrical shape, which determines the light characteristics of the fixture. The fixture head is rotatable and can be turned 60 degrees to the sides. The unique quality of the design idiom has made the fixture a modern classic. The luminaire backplate includes a switch.

**Finish**  
Blue/green, yellow/green, petroleum, red or sand. Black, graphite grey or white, wet painted.

**Material**  
Shade: Spun steel. Wall box: Spun steel. Arm: Steel.

**Mounting**  
Cable type: Vinyl cord with plug. Cable length: 2.4m. Light control: Switch in wallbox.

**Weight**  
Max. 1kg.

**Class**  
Ingress protection IP20. Electric shock protection II w/o ground. ⚠

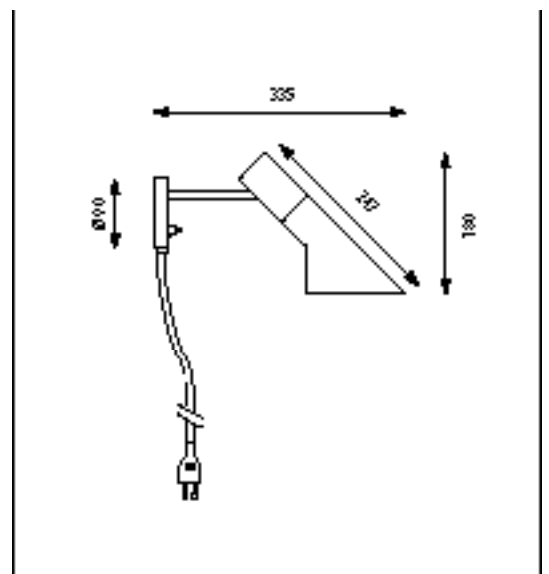

Product code	Light source	Finish	Cable type
AJ-W	1x40W D45 Frosted E14	BLUE/GREEN YELLOW/GREEN PETROLEUM RED SAND BLK GRAPH GREY WHT	BLK PL WHT PL

Info notes:  
Find energysaving alternative light sources on [www.louispoulsen.com](http://www.louispoulsen.com).

