



Weblink
1414

Project page
356

Excalibur Hotel & Spa, Las Vegas, Nevada, USA. Architect: Klai Juba Architects. Lighting designer: Klai Juba Architects. Photo: Clearlight

Design
Kurt Nørregaard

Concept
Oslo Uplight creates indirect lighting, and the light emitted between the shades produces a visually comfortable ambience. Its lighting characteristics make it ideal for accent lighting.

Finish
White, wet painted.

Material
Shades: Spun aluminium. Diffuser: Frosted, vacuum formed acrylic. Back plate: Punched steel.

Mounting
Terminal block: HF: 1x3x2,5mm², HF-D: 1x5x2,5mm². Cable entries: 2x rear entries, Ø 20mm. Looping: Approved, max. 3x1,5mm².

Weight
Max. 3kg.

Class
Ingress protection IP20. Electric shock protection I w. ground. ⚡

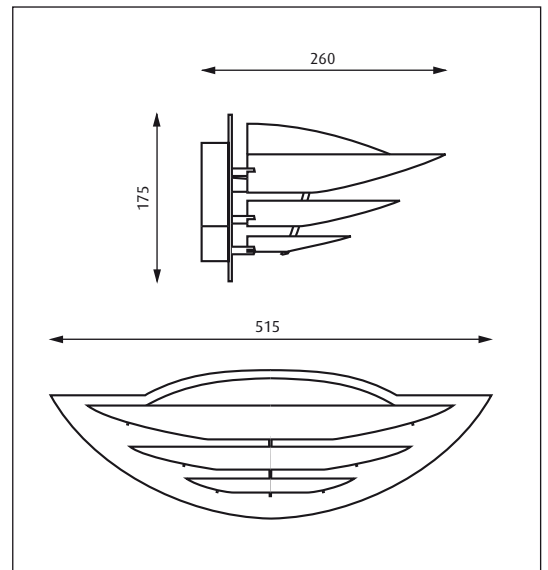

Product code	Light source	Finish	Lighting control
OS-W	1x42W TC-TEL GX24q-4 HF-D 1x26W/32W/42W TC-TEL HF	WHT	NONE DALI/DSI/SWITCH-DIM/SMART-DIM DIM 1-10V

Variant notes:
Dimming only available with 1x42W HF-D. HF only available with no light control.



Page 91

Page 56

Page 55