



etranger di costarica. Shop at AXIS Building, Tokyo, Japan. Photo: Shinji Aratani

**Weblink**  
1429

**Design**  
Poul Henningsen

**Concept**  
PH 2/1 Wall provides soft lighting. PH 2/1 is designed on the principle of a reflecting multi-shade system, producing glare-free lighting. The shade design is based on a logarithmic spiral, with the centre of the light source placed in the spiral's focal point.

**Finish**  
White opal glass. High lustre chrome plated.

**Material**  
Shades: Mouth-blown white opal glass. Wall box: High lustre chrome plated, spun brass. Suspension: High lustre chrome plated, spun aluminium. Arm: High lustre chrome plated, brass.

**Mounting**  
Cable length: 2.9m. Light control: Switch in wallbox.

**Weight**  
Max. 1.5kg.

**Class**  
Ingress protection IP20. Electric shock protection II w/o ground. ▽

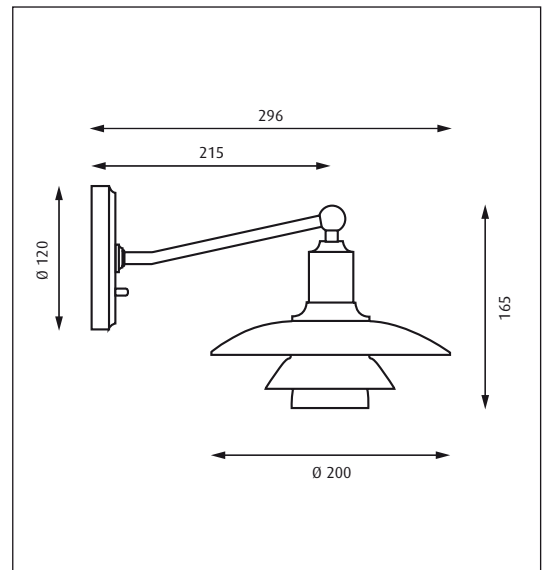

Product code	Light source	Finish
PH21-W	1x40W D45 Frosted E14	WHT OPAL GLASS

Info notes:  
Find energysaving alternative light sources on [www.louispoulsen.com](http://www.louispoulsen.com).



Page 92



Page 93

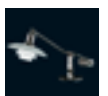

Page 123