

semi-recessed & surface



Weblink
1435

Project page
356

Sparkasse Mittelmosel, Bernkastel, Germany. Architect: Josef Schmitz Hödeshof.
Photo: Bent Ryberg/Planet

Design

Kurt Nørregaard

Concept

Oslo Round Wall/Ceiling provides indirect and direct general lighting, and the light emitted between the shades produces a visually comfortable ambience.

Finish

Aluminium, brushed and coated. White, wet painted.

Material

Shades: Spun aluminium. Diffuser: Sandblasted glass. Wall box: Spun steel. Struts: Die cast aluminium.

Mounting

Terminal block: 1x3x2.5mm² (HF-D: 1x5x2.5mm²). Cable entries: 2x rear entries, Ø 20mm. Looping: Approved, max. 3x1,5mm² (HF-D: 5x1,5mm²).

Weight

Max. 3kg.

Class

Ingress protection IP20. Electric shock protection I w. ground. ⚡

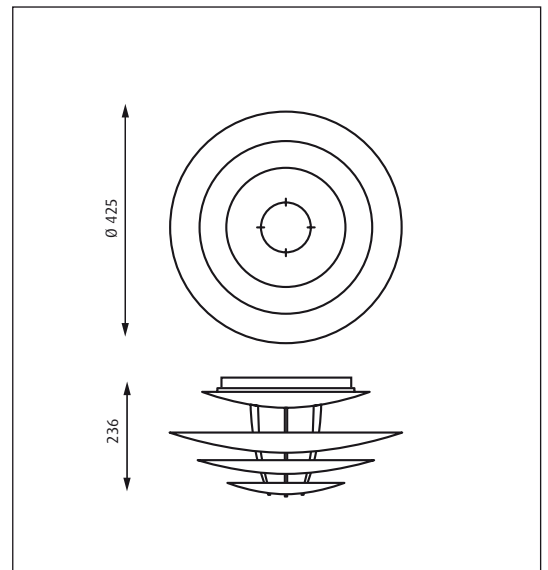

Product code	Light source	Finish	Lighting control
OS-RO-WC	1x42W TC-TEL GX24q-4 HF-D 1x26W/32W/42W TC-TEL HF	WHT	NONE DIM 1-10V

Variant notes:

Dimming only available with 1x42W HF-D.



Page 147



Page 91



Page 55