



Weblink
1473

Mandalay Bay Hotel & Casino. Las Vegas, Nevada, USA. Architect: Klai Juba Architects.
Lighting designer: Klai Juba Architects. Photo: Clearlight

Design

Alfred Homann

Concept

Pulsar 135 is able to provide general lighting in a space. The major part of the light is directed downward, but, depending on the chosen conical shade, the lighting characteristics vary from diffuse to direct lighting.

Finish

Metallic, wet painted. White opal acrylic.

Material

Ceiling ring: Injection moulded PBT. Shade: Metallic, injection moulded acrylic or injection moulded white opal acrylic. Housing: Clear lacquer, extruded aluminium.

Mounting

Recessed: Ceiling cut-out: Ø 150mm. Surface: Mounted directly on the ceiling. Ceiling thickness: 1-50mm. Terminal block: 1x3x2.5mm². Cable entries: 1x rear entry Ø 18mm. Looping: Not approved.

Weight

Max. 1.5kg.

Class

Ingress protection IP20. Electric shock protection I w. ground. ⚡

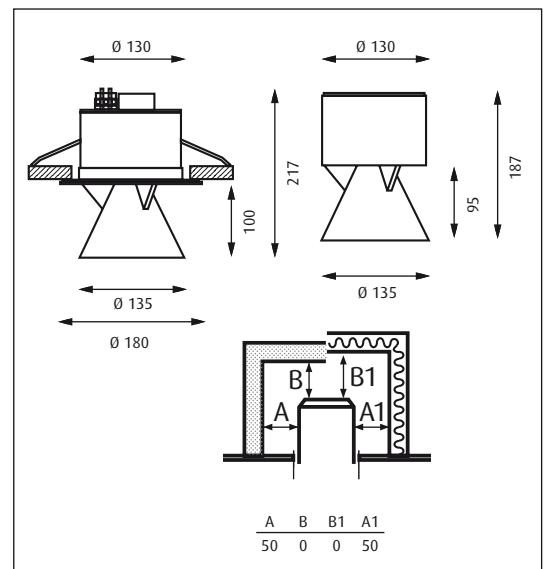

| Product code | Light source | Finish | Shade | Mounting |
|--------------|---|--------|-------------------------|-----------------------------|
| PUL-135-C | 1x18W TC-DEL G24q-2 HF 1x20W HIT-CRI G8.5 HF | MET | MET ACRYL OPAL ACRYL | RECESSED SURFACE MOUNTED |

Info notes:
All variants can be delivered with light source and/or 2m cable + plug.



Opal Acryl



Metal Acryl



Surface
mounted

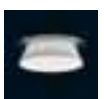

Page 59