

QUEEN TITANIA

alberto meda, paolo rizzato

D17Q

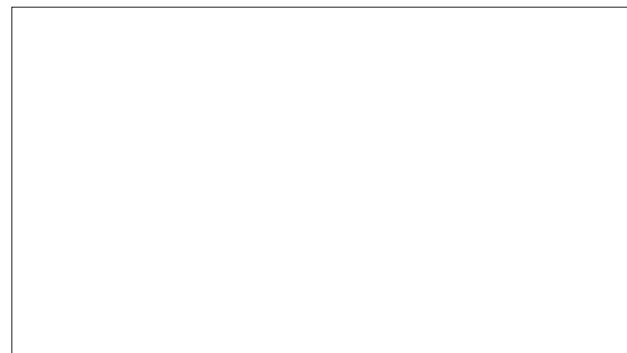
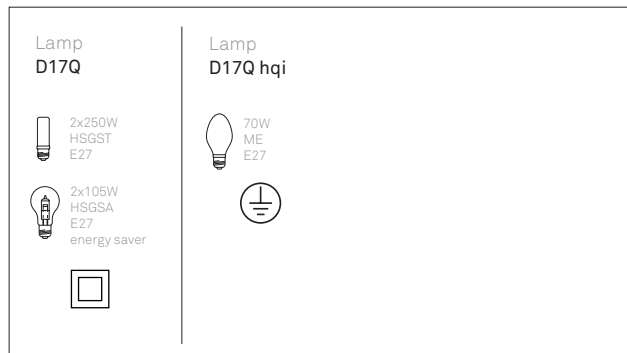
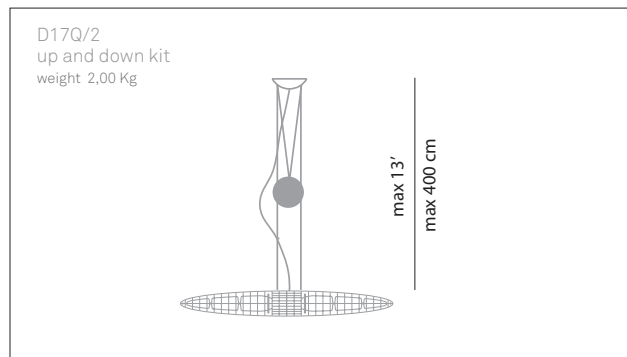
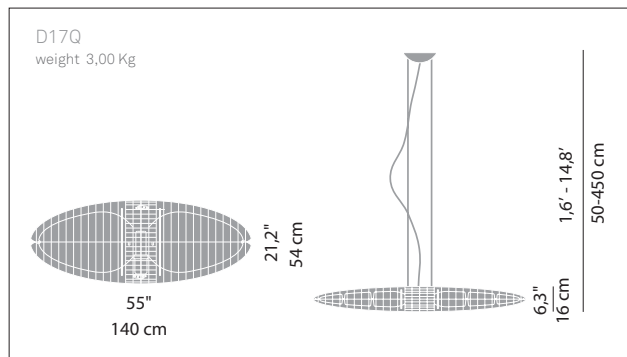

Materials
steel bearing structure aluminium lamellar shell

Structure finishes
● natural aluminium

Filters
● yellow ● violet ● red ● green ● blue

Note
spherical counterweight for up-down adjustment may be inserted or removed at any time

