

2011

pdf



Agatha Book

REV-08-2011

lzf
HANDMADE



AGATHA

Luis Eslava Studio

Agatha, the lamp that blooms.

Agatha, created by Spanish designer Luis Eslava for LZF, is a hanging lamp whose shape is achieved through the concentric superposition of materials. Same as in every LZF object, its lines remind us of those we find in nature: a flower, a tree, an animal. Light in aspect, Agatha suggests simplicity and originality. This lamp “blooms”, forming a semi-spherical object, in two different sizes: 76 cm x 37 cm and 140 cm x 80 cm, or expanding to form a full sphere: 76 cm x 76 cm. Available in 8 different finish tones, Agatha can be adapted to a wide range of spaces: private homes, contract, ephemeral settings, and many more.

Agatha, la lámpara que florece

Agatha, diseñada para LZF por el español Luis Eslava, es una lámpara de suspensión cuya forma nace de la superposición concéntrica. Como ocurre en todas las creaciones de LZF, sus líneas nos recuerdan a las que encontramos en la propia naturaleza: una flor, un árbol, un animal... De aspecto ligero, transmite sencillez y originalidad. Esta lámpara “florece” en un sentido semiesférico - en dos tamaños diferentes, 76cmx37cm y 140cmx80cm - o en una total expansión circular - 76cmx76cm -. Disponible en 8 acabados -tonos- distintos, Agatha se adapta a multitud de espacios: hogar, contract, montajes efímeros, etc.

AGATHA Luis Eslava Studio

PENDANT
SUSPENSIÓN

INFO

Electrical

Packaging

Dimension

ATA SP CHW



Shade / Pantalla

Natural wood /
Madera natural

CHW colors:



see chart / ver gráfico

Awards / Premios



HD Las Vegas 2011



WORLD

1 x 20 w
E-27
Ø95
CFL globe /
Globo bajo consumo



USA

1 x Globe CFL 15W
Medium Base

Up-Charge Option
1 x 15W CFL GU-24



Box / Caja:
8,5 Kg
0,421 m³
75x75x50 cm

10 Lb
Box size:
30x30x20"

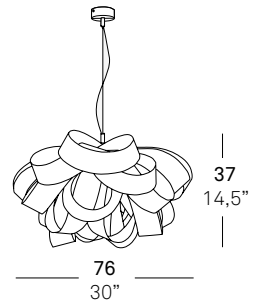

ATA SB CHW



2011 LIGHTING AWARDS 2011

World Architecture
Awards 2011



WORLD

6 x 11 w
E-27
Short CFL
Double tube /
Bajo consumo



USA

6 x Spiral CFL 11W
Medium Base

Up-Charge Option
6 x 11W CFL GU-24



Box / Caja:
12 Kg
0,421 m³
75x75x75 cm

25 Lb
Box size:
30x30x30"

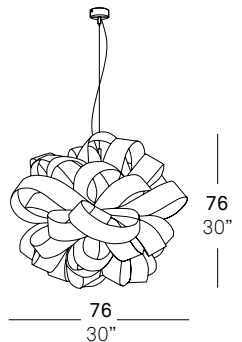

ATA SG CHW



WORLD

3 x 20 w
E-27
Ø95
CFL globe /
Globo bajo consumo



USA

3 x Globe CFL 15W
Medium Base

Up-Charge Option
3 x 15W CFL GU-24



Box / Caja:
13,6 Kg
0,938 m³

30 Lb
Box size:
40x40x36"

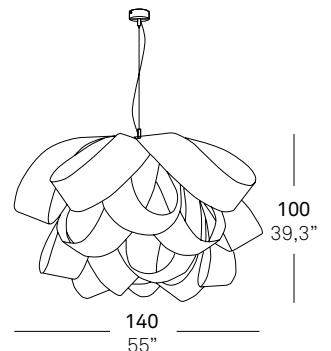

AGATHA Luis Eslava Studio

FAMILY / FAMILIA

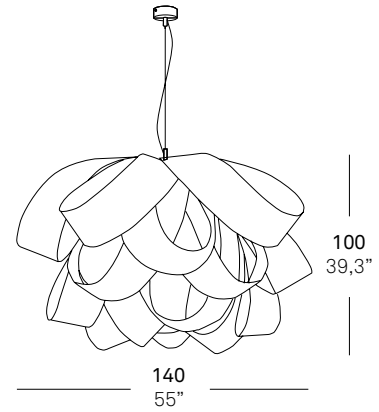
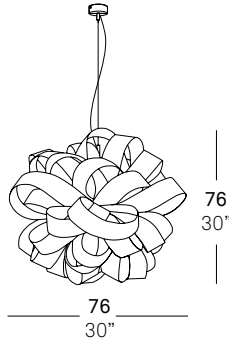
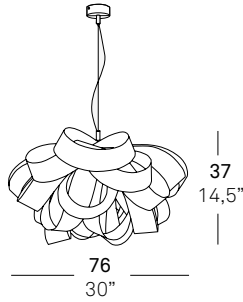

SHADE FINISHES / ACABADOS PANTALLAS

REF. CHW

Natural timber veneer **Madera natural**



CHW-20
American white wood
Bolivar blanco

CHW-25
Orange
Naranja

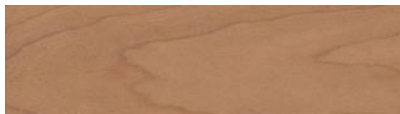

CHW-21
Cherry
Cerezo

CHW-26
Red
Roja



CHW-22
Beech
Haya

CHW-27
Green
Verde



CHW-24
Yellow
Amarillo

CHW-29
Grey
Gris









Agatha
Luis Eslava Studio



Agatha
Luis Eslava Studio



Agatha
Luis Eslava Studio



Agatha
Luis Eslava Studio

Handmade



Agatha
Luis Eslava Studio



Agatha
Luis Eslava Studio

