

Technical Data SIT-IT Executive AIR

SitLand

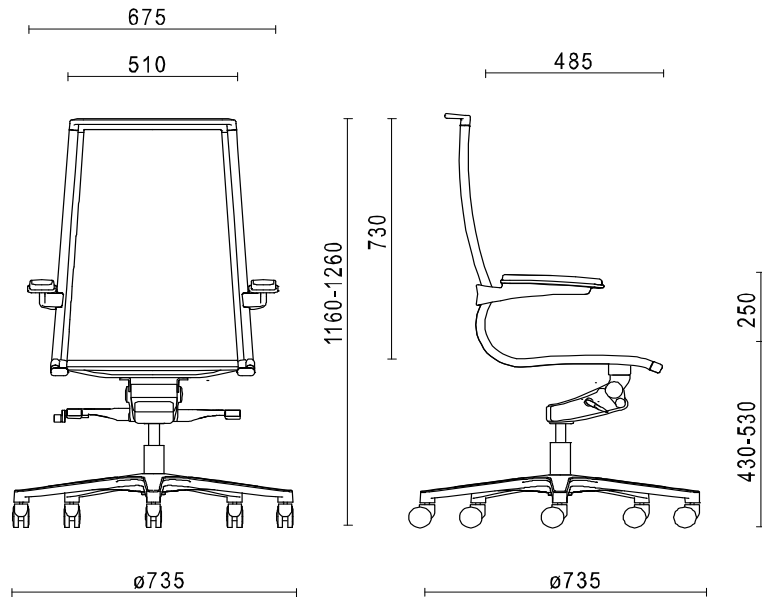

Components

Technical Features

Casters	Casters are realized in polyamide black colour ø65, free or rubbered and self-braking or hollow casters ø65, rubbered and self-braking, grey colour.
Base	5-star base with wide support diameter of ø735 mm. Base made of die-cast aluminium with the following possible finishes: polished, chromed and aluminium paint + transparent anti-scratch treatment.
Gas-lift	The gas-lift meets the requirements of DIN 4550 norm and it makes it possible to have a seat-height adjustment corresponding to a 100mm run. Available with double enhanced springs, chromed finish.
Dynamic Mechanism	The dynamic mechanism provides a synchronized movement with advanced pivot and the maximum span angle of the seat body is 16°. Complete with anti-panic device and back resistance adjustment device according to the user's weight or personal preference (see paragraph concerning Adjustments for instructions for use).
Structure	The structure of the seat is designed in order to get the most in terms of resistance. It is made of high-resistance chromed steel tube internally coupled with a polished and chromed extruded aluminium profile. Complete with proper chromed ABS terminals and with a polished and chromed die-cast aluminium handle. Available with aluminium paint finish + transparent anti-scratch treatment too.
Mesh	Highly elastic and tenacious mesh fabric ensuring high performances in terms of comfort and transpiration, coupled to the seat by a special bearing cloth and a soft middle cushion.
Fix Armrests	Fix armrest made of polished and chromed die-cast aluminium or with aluminium paint finish + transparent anti-scratch treatment. Available with armrest top made of soft complete polyurethane black colour or with top made of black shockproof plastic material.

Adjustments

Dynamic Mechanism knob adjustment



The dynamic mechanism gathers all the main seat functions control devices. While sitting, the following are reachable: on the right, the lever to adjust the seat height from the floor; on the left, the lever to have the conditions of oscillation, free or fixed in the 5 desired position. In the middle, the spring knob making it possible to adjust the back resistance according to the user's weight or personal preference. The seat meets any safety requirement thanks to the mechanism complete with anti-shock system.

Dynamic Mechanism handle adjustment



The dynamic mechanism gathers all the main seat functions control devices. While sitting, the following are reachable: on the right, the lever to adjust the seat height from the floor; on the left, the lever to have the conditions of oscillation, free or fixed in the 4 desired positions. On the right, a pullout handle makes it possible to adjust the resistance of the oscillation according to the user's weight or personal preference. The seat meets any safety requirement thanks to the mechanism complete with anti-shock system.